

Instruction Manual



Shay West Side Lumber #15



ACCUCRAFT COMPANY
33268 Central Avenue
Union City, CA 94587
Tel: 510 324-3399
Fax: 510 324-3366
email: info@accucraft.com
Copyright 2005

 **ACCUCRAFT TRAINS**
MUSEUM QUALITY BRASS MODELS



General information about your Accucraft Model:

This accurately detailed model is constructed of brass and stainless steel. A large Pittman gearhead motor powers all drivers through a metal gear box with steel gears. The museum quality finish and lettering represents this locomotive as it would have looked in the 1950's.

The Shay locomotives were developed by Ephraim Shay. His first successful engine that we could recognize today as a Shay locomotive was produced in 1880 by Lima Machine Work (later Lima Locomotive Works), who would go on to produce approximately 2, 700 Shays up until 1945, when production ceased.

Shay locomotives are unusual in that they are powered by a steam engine of either two or three cylinders mounted vertically near the cab on the right side of the locomotive. The boiler was offset on the frame to counterbalance the weight of the engine. The engine drove a drive shaft that, through flexible couplings, turned bevel gears that engaged the wheels. This type of engine is known as a geared engine; since the wheels turn at a different rate from the engine, due to the gear ratio. This arrangement made the engine very flexible and able to negotiate raggedy track without derailing.

Because of this characteristic, as well as its great power, it was an exceeding popular engine with logging companies and other industries that relied on tough engines in unforgiving environments.



NOTES:

NOTES:



The locomotive has carbon brush pickups for both rails, to insure reliable operation when using track power.

Disassembly of this large and complex model is not recommended. However, if absolutely necessary, the 1.6mm hex bolts and nuts can be turned with a nut driver sized for US 00-90.

Please take care in lifting this large and heavy model. It is recommended that the locomotive be picked up by grasping it under the frame on both ends.

Technical Specifications

Scale	1:20.3
Gauge	45mm Gauge
Total Weight	9.25 lbs.
Length	16in.
Width	4.75 in.
Height	7in.
Minimum Radius	1.2 M, 48 in.
Power	0-24V, Pittman Gearhead Motor
Features	Constant Lighting

* Be sure to leave at least a 3" clearance (measured from the inner rail) on the 46 1/4" radius curve to allow for overhang.

The following parts are packaged separately

- M2 hex head screws
- 2mm hex head screw driver



Model Features

This limited production model has been handcrafted for Accucraft Trains by AMMC, one of the most respected makers of large scale brass models. This museum quality model features:

- Full cab interior details.
- Detailed boiler with fittings, domes, pipes, and handrails
- Operating steel drive rods, valve gear and cross heads
- Protypical livery and lettering

- Steel helical gears in a die-cast transfer box

Caution!

This model is an accurate replica of the original locomotive. It has sharp and moving parts. The locomotive drive rods are stainless steel with sharp edges.

OPERATORS MUST NOT COME IN CONTACT WITH A MODEL THAT IS BEING POWERED AT ANY TIME. UNDER NO CIRCUMSTANCES SHALL ACCUCRAFT TRAINS BE RESPONSIBLE FOR ANY INCIDENTAL OR CONSEQUENTIAL DAMAGES ARISING IN REGARD TO ANY ACCUCRAFT PRODUCT.



NOTES:



2. Lift the metal case from the cardboard box.

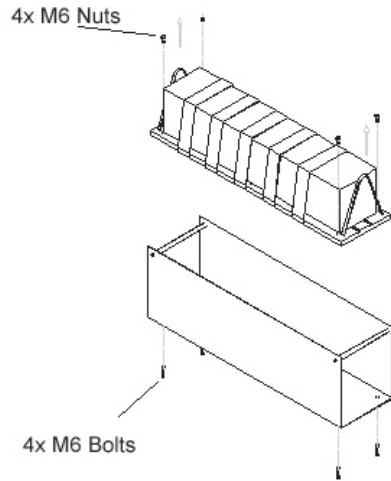

3. The locomotive is firmly taped to a 1/2" wood board which is then fastened to the metal case with 4 M6 bolts. The bolts must be removed before lifting the locomotive with wood board from the metal case.

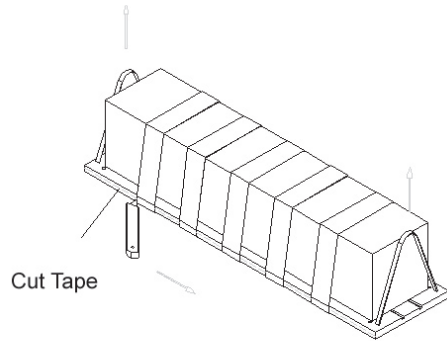

4. Place taped locomotive on a level flat surface. Carefully cut the tape along the wood board side surface. Be sure to cut both sides of the wood board. Slowly lift the tape from the locomotive.

Be very careful with small parts. The tape cannot be re-used to re-pack the model. Use new packing tape if necessary.



Maintenance

Tools you will need for maintenance

- 1.5 mm allen wrench
- 1.6 mm and 2 mm hex wrenches
- Flat head screw driver

Lubrication

Please lubricate your Accucraft Shay before attempting to operate.

With a bit of care, your Accucraft Shay should give you many years of pleasure and reliable service. Lubrication is of prime importance on a model of this type with so many moving parts. Always use quality lubricants. This should not be a problem, as there are many modern lubricants available in hobby and sport shops.

Light oil such as Labelle #108 or Hoppe's Gun Oil will do a good job on lubricating most of the moving parts.

For pistons and slides, a heavier lubricant such as Labelle #102 would suffice.

For gears use gear grease such as Permatex Super Lube or another hobby gear lubricant.

To access the many moving parts of this model it is best to carefully place it on its side on a soft towel or foam sheet. A drop of light oil on every moving part is necessary, and there are many on this locomotive. Be sure to lubricate all the crosshead



slides, piston rods, etc. that are visible to you. Do not over lubricate, for excess oil only picks up unwanted dirt. Be careful to keep the lubricant off the painted surfaces as this will leave a shiny appearance on the area it touches.

The main gear box is lubricated in the factory, and will not need any attention when you first run your model. However, in time, you should make sure that the gears are well lubricated with a technical gear grease. The gear box cover is held on with screws, and removing it will allow you to access all the gears and bushings that need lubrication. Take note of how the cover came off and replace it exactly the way it was when you started. Lubrication should be done every 25 hours of operation.

Operation

After following the recommended lubrication procedures your locomotive is ready to provide many years of reliable operation.

We recommend that you use a D.C power supply with a capacity of 2.5 amps or larger.

Always pick your model up by grasping it under the frame on both ends. It is a very heavy model so make sure that you grasp it firmly.

Electrical Pickup

Your Accucraft model is powered by the DC voltage off the track. All wheels are insulated on both sides of the locomotive, and the electricity is picked up with 8 pickup wheels. Be sure to clean electrical pickup units before each operation.

Replacement electrical pickup units can be ordered from Accucraft Trains.

General maintenance

Clean the exterior surfaces of your locomotive with a clean, soft, lint free



Unpacking Accucraft Locomotive

Accucraft locomotives are fine scale brass models with small parts. To provide maximum protection from shipping damage, we carefully pack the models in metal cases.

We ship via UPS with insurance coverage to its full value. Please contact UPS if package is damaged.

Each locomotive is packed under UPS guidelines for shipping. We do not warrant any damage resulted from re-packaging by any party other than Accucraft Trains.

Please read the following directions before unpacking your locomotive.

1. Remove foam around the locomotive. Slide the inner box cover to the side, and carefully open the inside cardboard box with a cutting knife.

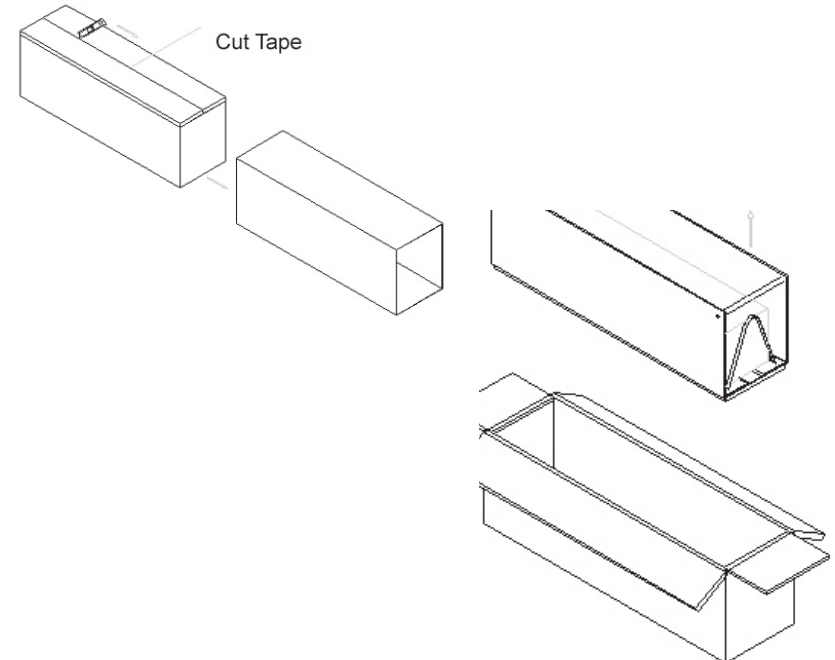

Figure 3